



CAPLE CARE

FREE 2 YEAR  
PARTS & LABOUR  
GUARANTEE



## ISLAND HOOD

### PRODUCT CODE

CGi921

### DIMENSIONS

← w:900mm  
h:920-1240mm

### PERFORMANCE

**e** Energy class A  
Fluid dynamic efficiency A  
Light efficiency C  
Grease absorption D  
Annual Consumption  
42kWh/yr  
Max. extraction 617m<sup>3</sup>/h  
Max. noise level 68dB[A]

### FEATURES

- Touch controls
- 3 Speeds
- 4 x 1.5W high intensity LED lights
- Aluminium grease filters
- Required ducting size 150mm
- Supplied with 2m length of semi-rigid ducting
- Recirculation kit available

### OPTIONAL EXTRAS

- Recirculation kit [CAP61CF]
- Visit [caple.co.uk](http://caple.co.uk) for full range

### DIMENSIONS

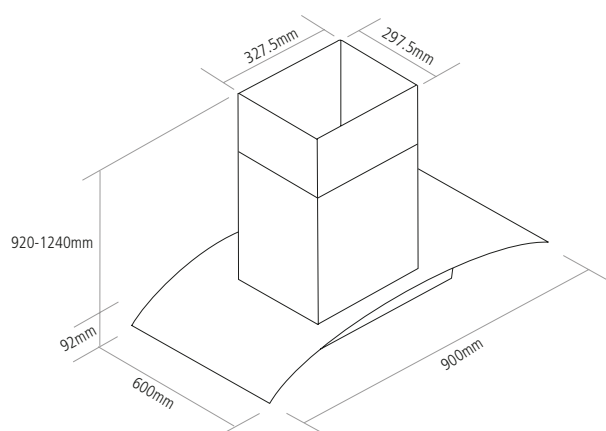

### FINISH AVAILABLE

■ Stainless steel with curved clear glass