



Extraction Motor Instruction Manual

MODELS:

DDMEXT21, DDMEXT25,
DDMEXT28, DDMEXT31, DDMEXT40



CONTENTS

| | |
|--------------------------|----|
| Safety Instructions | 3 |
| Environmental Protection | 5 |
| Useful Warnings | 6 |
| DDMEXT21 & DDMEXT25 | 8 |
| DDMEXT31 | 11 |
| DDMEXT40 | 14 |
| DDMEXT28 | 17 |
| Caple Contact Details | 20 |

WARNINGS

The air outlet of the appliance must not be connected to a flue which is used for exhausting other fumes from appliances, such as a central heating, boilers etc. For the external exhausting of the fumes, comply with the regulations in force. Ventilate the room suitably according to the laws in force when the appliance is working together with gas, oil or coal burning appliances, at the same time. The motor of the peripheral exhausting group is powered by the cooker-hood placed in the kitchen. Before connecting the cooker hood to the mains supply, make sure that the voltage indicated in the rating plate corresponds to the mains voltage in the home. Before carrying out any sort of maintenance or cleaning operation, make sure that the appliance is disconnected from the electrical mains. An appropriate maintenance ensures a good working and a good performance in the long run. The external motors type DDMEXT are built in class I, therefore they must be earthed.

APPROPRIATE USE

- This appliance is intended to be used in household and similar applications such as:
 - › Staff kitchen areas in shops, offices and other working environments.
 - › Farm Houses.
 - › By clients in hotels, motels and other residential type environments.
 - › Bed and breakfast type environments.



ENVIRONMENTAL PROTECTION

Waste electrical products should not be disposed of with household waste. Please recycle where facilities exist. Check with your Local Authority or retailer for recycling advice. This appliance is marked according to the European Directive on Waste Electrical and Electronic Equipment [WEEE].

By ensuring this product is disposed of correctly, you will help prevent potential negative consequences for the environment and human health, which could otherwise be caused by inappropriate waste handling of this product. The symbol on the product indicates that this product may not be treated as household waste. Instead it shall be handed over to the applicable collection point for the recycling of electrical and electronic equipment. Disposal must be carried out in accordance with local environmental regulations for waste disposal.

For more detailed information about treatment, recovery and recycling of this product, please contact your local council, your household waste disposal service or the retailer where you purchased the product.

CE DECLARATIONS OF CONFORMITY **CE**

This appliance has been manufactured to the strictest standards and complies with all applicable legislation, Low Voltage Directive [LVD] and Electromagnetic Compatibility [EMC].

UKCA DECLARATIONS OF CONFORMITY **UK CA**

This appliance has been manufactured to the strictest standards and complies with all applicable legislation.

WARRANTY

Your new appliance is covered by warranty. The warranty card is enclosed - if it is missing, you must provide the following information to your retailer in order to receive a replacement: date of purchase, model and serial number [placed on the inside of the appliance storage drawer]. Registration can also be completed online by visiting www.caple.co.uk.

Ensure you keep your warranty card safe, you may need to show it to Caple Service together with proof of purchase.

If you fail to show your warranty card you will incur all repair charges.

Spare parts are only available from Caple Service and spare parts authorised centres.

TECHNICAL FICHE

This appliance conforms to all current and applicable energy regulations. To view the technical Fiche that supports the energy labelling data, please visit the product page on our website www.caple.co.uk

USEFUL WARNINGS:

- › Use an air outlet pipe with a maximum length not higher than 5 meters.
- › Limit the number of bends in the exhausting pipe as every bend reduces the performance up to one linear meter. [If you use 2 90° bends, than the length of the pipe has got to be higher than 3 meters].
- › The material for the pipe has to be approved by an authorised company.
- › It is important to avoid changes in the diameter [A minimum 150mm diameter ducting must be used].
- › Read carefully the manual of instructions and installation of the unit.-
- › Caple will not be responsible for problems of capacity and/or noise level due to the missed respect of the warnings included in the instruction manual.
- › DDMEXT25 / 40 are equipped with a 200mm diameter hole for the exhausting pipe. If the unit that has to be connected to the remote fan already equipped with a 200mm diameter hole, then it is recommended to use a pipe with the same diameter in order to get good performance. Otherwise, if the unit is equipped with a 150mm diameter hole, then it is recommended to use the joint [from 200mm to 150mm], already supplied with the unit. The electric box cable should not be cut or joined together with other cables, since it could compromise the proper working and the safety conditions of the appliance. Furthermore, this will invalidate the manufacturer's warranty coverage.

CAUTION:

In order to know the exact power input in [WATT] of the motor being used, the technician shall tick the box corresponding to the DDMEXT unit used on the label placed next to the rating label, as shown in the figure below.

| Motor | | caple | |
|--------------------|--------------------------|---------------|--------------------------|
| DDMEXT21 275W | <input type="checkbox"/> | DDMEXT40 490W | <input type="checkbox"/> |
| DDMEXT30 190W | <input type="checkbox"/> | DDMEXT11 275W | <input type="checkbox"/> |
| DDMEXT31 220W | <input type="checkbox"/> | DDMEXT28 110W | <input type="checkbox"/> |
| DDMEXT25 250W | <input type="checkbox"/> | | |
| 90005150313 | | | |

WARNINGS:

As a result of the new EU65 "Energy label" and EU66 " Ecodesign" regulations issued by the European Commission, which came into force on January 1st, 2015, our products have been adapted to comply with these new requirements. All of the models complying with the energy label requirements, are equipped with new electronics including a timer device for suction speeds control, when the air capacity exceeds 650m³/h.

DDMEXT21 and **DDMEXT31** products have a timer control function activated at 4th speed for 6 minutes, if it is combined with a **DOWNDRAFT** or 5 minutes if it is combined with other products, such as ceiling hoods, wall hoods and island hoods. Once the above mentioned times elapse, the motor will switch to 3rd speed automatically.

DDMEXT40 and **DDMEXT25** products have a maximum air capacity higher than 650m³/h at both 4th and 3rd speed, therefore they will have the following by default timer control functions: **DDMEXT40** **DDMEXT25** with **DOWNDRAFT EM**

- › 4th speed is time controlled for 6 minutes, after which the product switches to speed 2.
- › 3rd speed is time controlled for 7 minutes, after which the product switches to speed 2.

DDMEXT40 and **DDMEXT25** with **CEILING- WALL AND ISLAND HOODS**.

- › 4th speed is time controlled for 5 minutes, after which the product switches to speed 2.
- › 3rd speed is time controlled for 7 minutes, after which the product switches to speed 2.

The energy consumption of the appliance in standby mode is lower than 0.5W.

DDMEXT21 & DDMEXT25

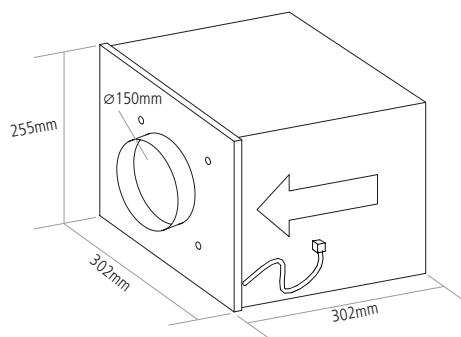

DDMEXT21

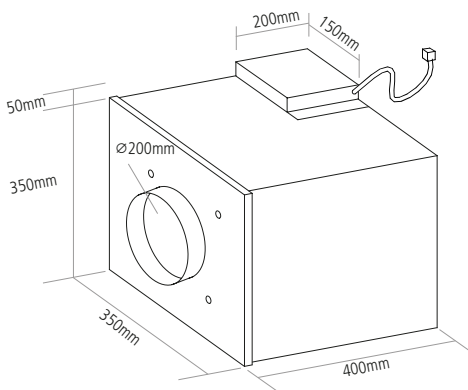

DDMEXT25

These products are designed to efficiently exhaust fumes and odours. They must be installed inside the house and connected to the cooker-hood, which is in the kitchen [Fig.1].

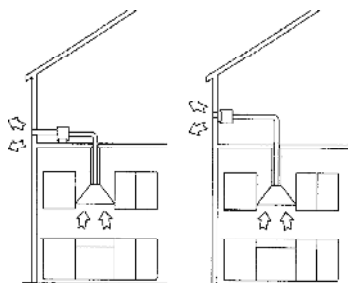

FIG.1

TYPES OF INSTALLATION:

To make the installation easy, the product can be fixed to the wall, the ceiling or the floor in a horizontal position [Fig.2] or vertically [Fig.3] to the fixing level.

NOTE:

For the vertical fixing, the brackets supplied can be used only on the longest side [Fig.4].

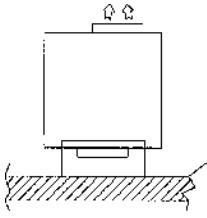

FIG.2

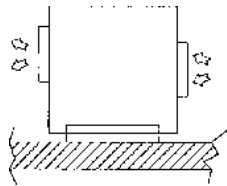

FIG.3

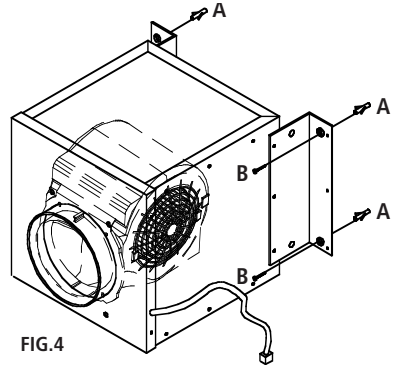

FIG.4

INSTALLING THE APPLIANCE:

After deciding the position and the type of installation, insert the anti-vibration rubber caps in the holes of the brackets supplied [Fig.5C].

The rubber caps must be put on the sides which are in contact with the wall.

Put the brackets [Fig.5A] on the extraction motor by matching its holes with those of the brackets. Fix with the screws supplied [Fig.5B].

Put the group on the point previously chosen for the installation and mark the points on the wall where the holes must be drilled.

Insert the dowels supplied in the holes [Fig.4A]. Put the extraction motor on the wall by matching the holes of the brackets with the plastic dowels. Screw with the screws supplied [Fig.4B].

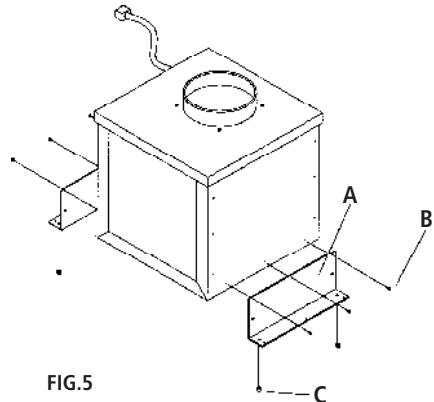

FIG.5

CONNECTING THE DUCTING:

The appliance has an inlet and an outlet to connect the ducting. Before connecting the ducting, check the direction of the air shown on the rating label [Fig.6]. Connect the ducting with appropriate fixings [ducting and fixings are not provided and are to be supplied by the installer]. The ducting [Fig.6A] must be connected with the cooker hood placed in the kitchen, and the ducting [Fig.6B] must be directed outside the building.

Connect the external motor's cable to the terminal board found inside the plastic box of the wiring. Make sure to respect the colours of the cables when performing the electrical connection [Fig.7].

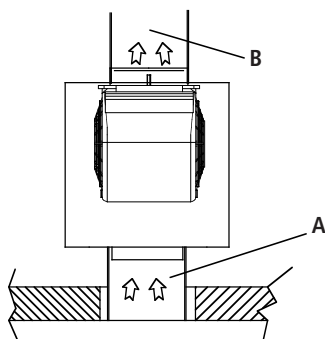

FIG.6

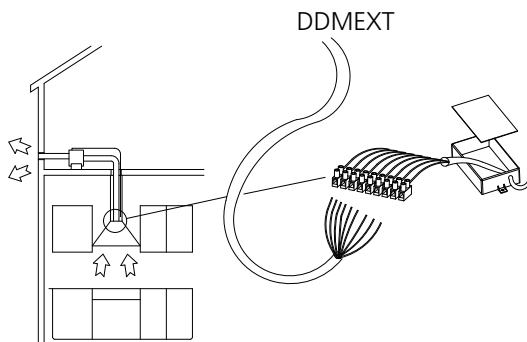
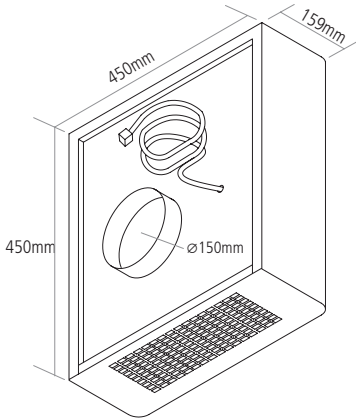

FIG.7

DDMEXT3 1



This product is designed to efficiently exhaust fumes and odours. It must be installed on the outside wall of the house and connected to the cooker-hood in the kitchen [Fig.8].

NOTE:

The Motor must be installed a minimum of 50cm from the floor to avoid back pressures from the extracted air.

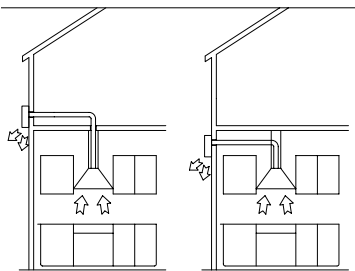

FIG.8

INSTALLATION:

This product is to be installed by a qualified technician. Using the appropriate drilling jig [Fig.9] drill all the holes marked on it into the external wall, by paying attention not to damage water pipes or power lines.

The holes on the wall are to be drilled with an 8mm bit. Insert, step by step, the following parts in the holes drilled:

- › The corresponding plastic dowels supplied [Fig.9A].
- › Two ducting channels [not supplied] in the hole of 160mm.
- › Plastic ducting of 40mm diameter [not supplied].

Before leaning the appliance against the wall, insert the supply cord in the plastic ducting.

Fix the appliance without the stainless-steel external body, which was previously removed from the motor block, by matching the holes of the motor block with the holes on the wall.

Tighten with the screws supplied [Fig.9B].

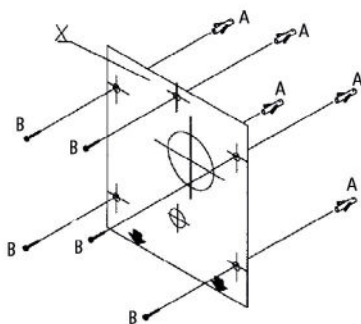

FIG.9

CONNECTING THE DUCTING:

The appliance has an air inlet to connect the ducting to an air outlet.

After fixing the appliance to the external wall, use rigid ducting to connect the motor to the appliance [Fig. 10].

NOTE:

Ducting and fixings are not provided and are to be supplied by the installer.

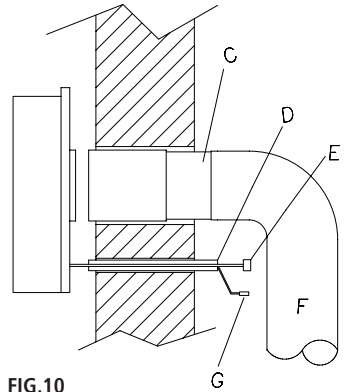

FIG.10

ELECTRICAL CONNECTION TO THE HOOD:

Connect the external motor's cable to the terminal board found inside the plastic box of the wiring. Make sure to respect the colours of cables when performing the electrical connection [Fig. 11].

In order to avoid water ingress, apply silicone to the product perimeter, close to the wall.

INSTALLING THE STAINLESS-STEEL EXTERNAL BODY:

Refit the stainless-steel body again, by matching the air exhausting grid with the air outlet of the motor block [Fig. 12].

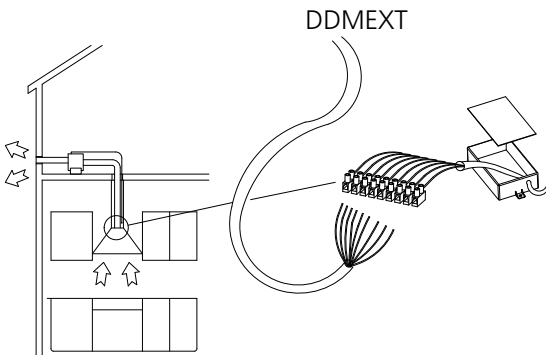

FIG.11

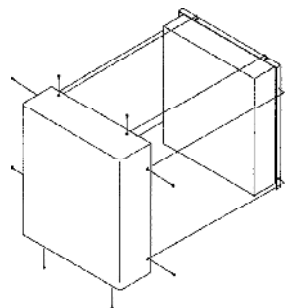
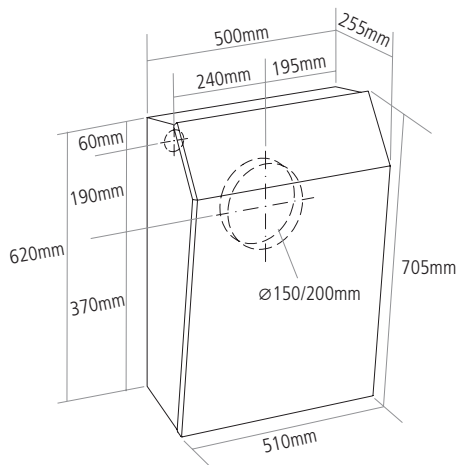

FIG.12

DDMEXT40



This product is designed to efficiently exhaust fumes and odours. It must be installed on the outside wall of the house and connected to the cooker-hood in the kitchen [Fig.13].

NOTE:

The Motor must be installed a minimum of 50cm from the floor to avoid back pressures from the extracted air.

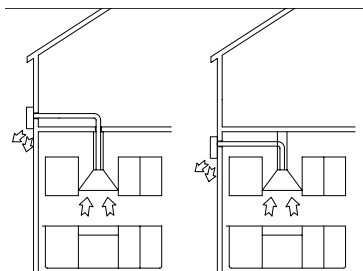

FIG.13

INSTALLATION:

This product is to be installed by a qualified technician. Using the appropriate drilling jig [Fig. 14] drill all the holes marked on it into the external wall, paying attention not to damage water pipes or power lines.

The holes on the wall are to be drilled with an 8mm bit. Insert, step by step, the following parts in the holes drilled:

- › The corresponding plastic dowels supplied [Fig. 14].
- › Two ducting channels [not supplied] in the hole of 200mm.
- › Plastic pipe of 40mm diameter [not supplied].

Before leaning the appliance against the wall, remove the stainless-steel cover using the 8 perimetrical screws [Fig. 15], then insert the supply cord in the plastic ducting.

Fix the appliance without the stainless-steel external body, which was previously removed from the motor block, by matching the holes of the motor block with the holes on the wall.

Tighten with the screws supplied.

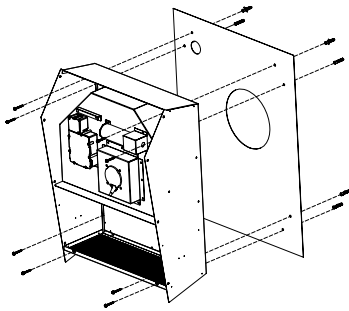

FIG. 14

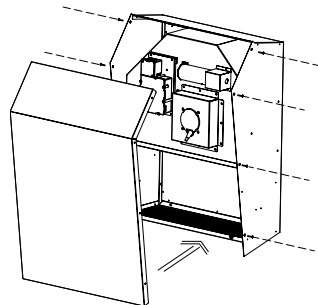

FIG. 15

CONNECTING THE DUCTING:

The appliance has an air inlet to connect the ducting to an air outlet.

After fixing the appliance to the external wall, use rigid ducting to connect the motor to the appliance [Fig. 16C].

Ducting and fixings are not provided and are to be supplied by the installer.

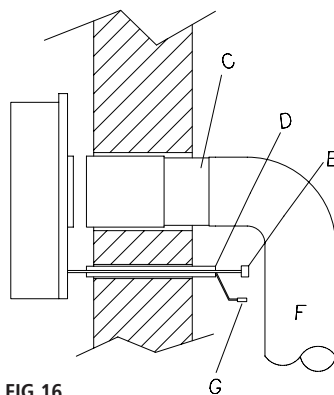

FIG. 16

ELECTRICAL CONNECTION TO THE HOOD:

Connect the external motor's cable to the terminal board found inside the plastic box of the wiring. Make sure to respect the colours of cables when performing the electrical connection [Fig. 17].

In order to avoid water ingress, apply silicone to the product perimeter, close to the wall.

INSTALLING THE STAINLESS-STEEL EXTERNAL BODY:

Refit the stainless-steel body again, by matching the air exhausting grid with the air outlet of the motor block [Fig. 18].

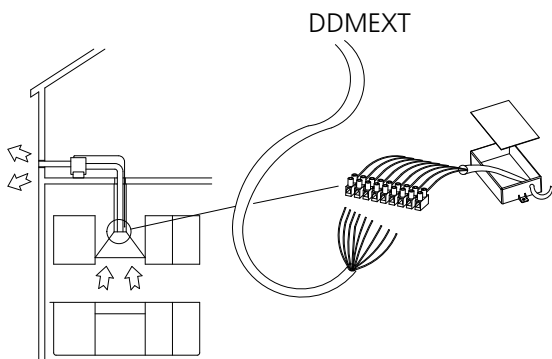

FIG. 17

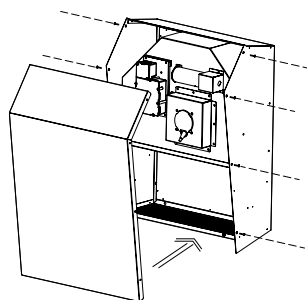
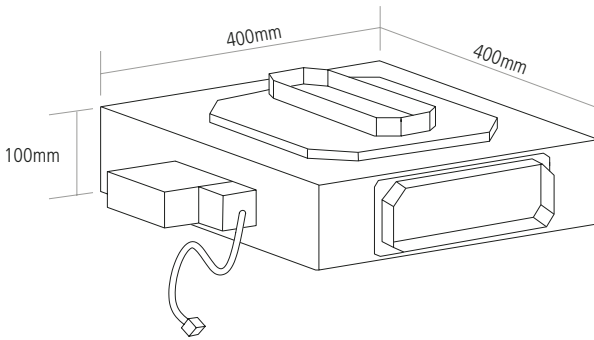

FIG. 18

DDMEXT28

This product has been designed to be installed under a kitchen cabinet, corresponding to the downdraft lower air outlet. This product can work only if it is used in combination with a Caple downdraft. This product is designed to efficiently exhaust fumes and odours. We recommend you use the product in Recirculation Mode only and to use a constant diameter piping of 150mm or similar sections.

We also recommend using ducting without elbows, as they negatively affect the performance of the appliance.



INSTALLATION:

Place the appliance under the downdraft, corresponding to the air outlet, as shown in [Fig.19].

All fittings are supplied with the appliance, along with a rectangular pipe that connects the downdraft to the DDMEXT28.

The appliance air outlet shall be connected to the cabinet in such a way that the air sucked in from the kitchen can be recirculated back into the room. This can be by means of reducing the plinth height around the whole island unit to allow air to escape into the room or by means of a vent in the plinth. Ducting to be connected from the DDMEXT28 to an air outlet grille/vent is not supplied with the appliance and should be purchased separately.

It is possible to direct the product air outlet according to your installation requirements, by rotating the air outlet flange as shown in [Fig.20].

The appliance is equipped with a 7-meter-long power cable, to be connected to the downdraft hood in the specific terminal board found inside the plastic black box [Fig.21].

With reference to the Energy Label standard and taking into account its performances, it is not necessary to equip the product with any time control device.



FIG.19

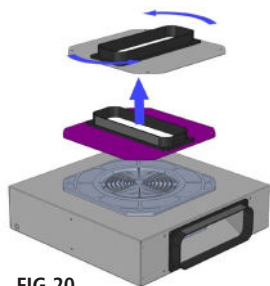

FIG.20

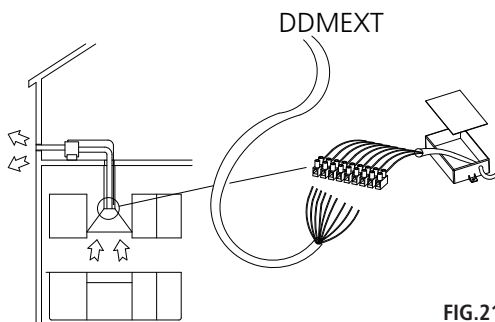

FIG.21





Caple Service
Fourth Way
Avonmouth
Bristol
BS11 8DW

T: 0117 938 1900
E: service@caple.co.uk
www.caple.co.uk